

REV.	ECN NO.	DESCRIPTION	DESIGN	DATE
A		INITIAL	Kai	2018.03.29

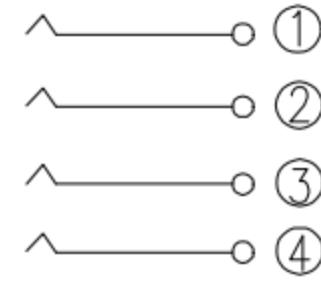

CIRCUIT

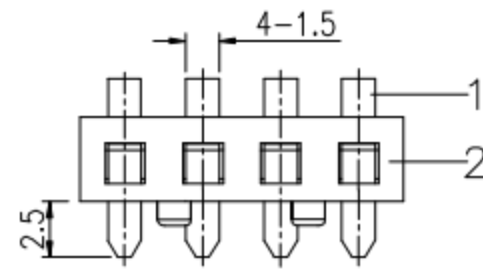
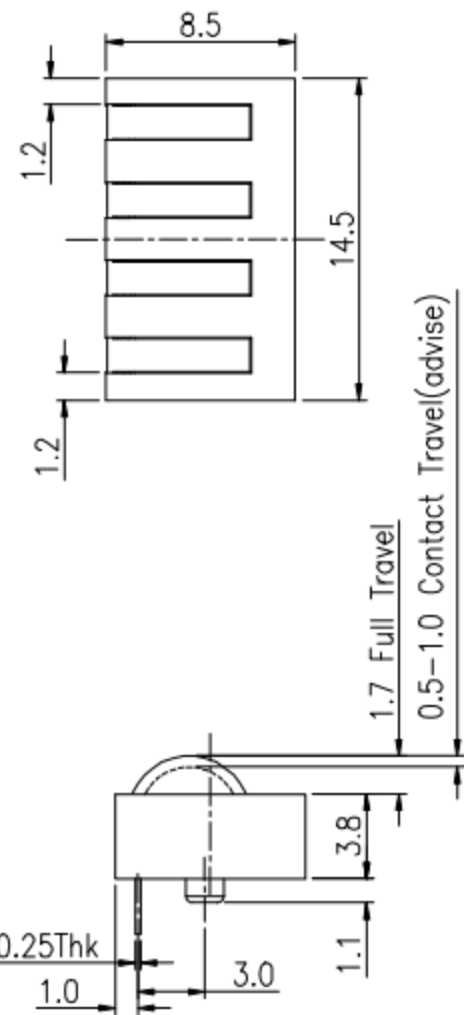
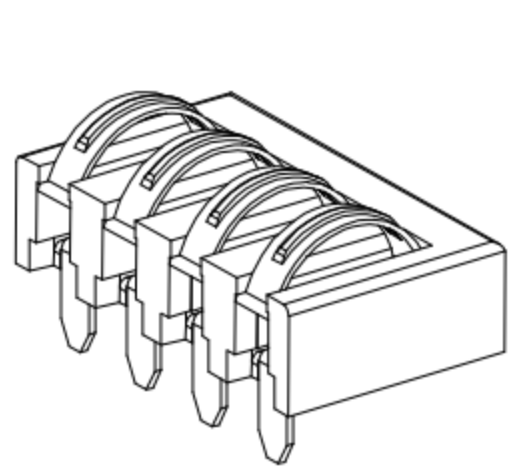
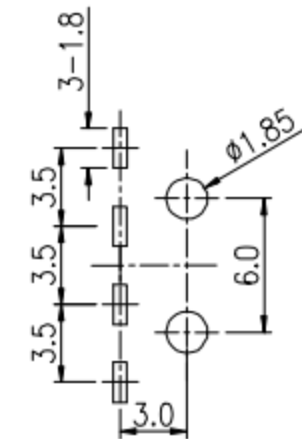
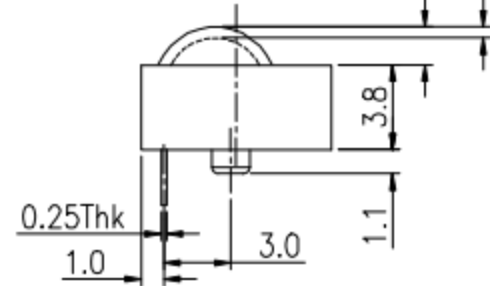
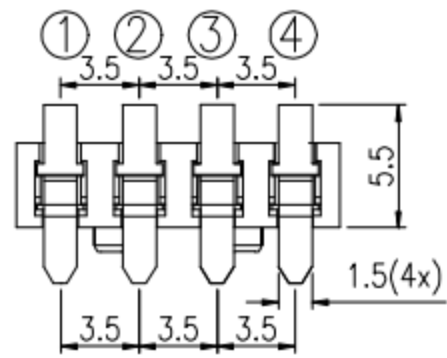

P.C.B LAYOUT

SPECIFICATIONS

- ELECTRICAL CHARACTERISTICS:
 - 1-1.RATING: DC 12V 3A
 - 1-2.CONTACT RESISTANCE: 20m Ω MAX(INITAL)
 - 1-3.DIELECTRIC WITHSTANDING VOLTAGE: 500V AC FOR ONE MINUTE
 - 1-4.INSULATION RESISTANCE: 100M Ω MIN, MEASURED BY 500V DC
- FORCE:0.6mm CONTACT TRAVEL:400gf Max.
- LIFE TEST:MECHANICAL LIFE TEST 20,000 CYCLES.
- TEMPERATURE RISE : 30°C MAX

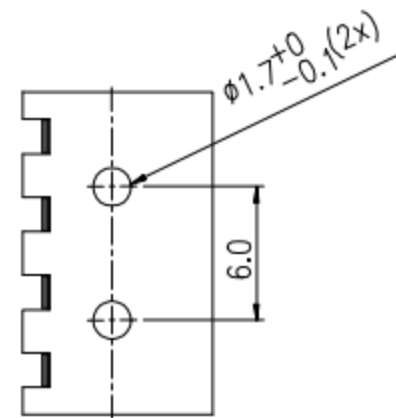

UNLESS OTHERWISE SPECIFIED TOLERANCES				东莞市高迪电子有限公司			
DECIMALS:		ANGLES:		DWG NO.	PART NAME:		
DIM	TOL	DIM	TOL	DESIGN:	PART NO.		
X.	±0.50	X.	±2°	CHECK:	REV. UNIT: SHEET:		
X.X	±0.30	X.X	±1°	APPROVED	A	mm	1/1
X.XX	±0.20	X.XX					
X.XXX	±0.10	X.XXX					

ITEM	PART NAME	Q'TY	MATERTAL	DESCRIPTION	REMARK
②	HOUSING	1	LCP		BLACK
①	CONTACT A	2	PHOSPHOR BRONZE 0.20T	Au PLATED	